

# Users manual



## HtCeramic programmable controller

HtCeramic 03/03 soft 3.02/rev. 3

**HTH8 s.r.o.**

Eimova 880, 572 01 Polička  
Czech Republic  
tel.: +420 461 619 515  
fax: +420 461 619 513

e-mail: [info@hth8.cz](mailto:info@hth8.cz)  
[www.hth8.cz](http://www.hth8.cz)

# 1 Introduction

---

CERAMIC is a temperature controller intended for the built-up to panel, format of device is ¼ DIN (96 x 96 mm). Enables programmable controlling with accordance to the requested curve or controlling to stp value. The controller is equipped with 1 input for measurement and 3 outputs. It can be enhanced with communication lines.

Users manual for controller CERAMIC is divided into particular chapters. When it is installed and put into operation we recommend proceed as follows:

## **If you are a final user, controller is in the default setting by the supplier**

If you are a final user, you will get the device in the customized operation and you can view and change only the parameters that you need for your own work on the controller.

If you are a new user of the device, focus on the following chapters:

- [Basic terms](#), here it is explained the key functions, displays, and so on.
- [Basic mode](#), the description of basic mode of controller.
- [User level](#), the description of parameters and menus of user level.
- [Program](#), all you need to know about editing a program.

## **You are carrying out the complete installation and setting of the controller**

In this case you proceed in accordance with the following chapters:

- [Installation](#), in this chapter it is described how to build in a controller into panel. [The controller is](#) designed to be mounted to the panel cutout. Slide the controller into the cutout and fix it with 2 flanges, that are supplied with the controller. The installation requires the access to the back of the panel.

## **Mounting dimensions**

- Width x height x overall length: 96 x 96 x 121 mm (including terminalboard).
- behind panel length: 114 mm (including terminalboard).
- Cutout in the panel: 91 x 91 mm.
- The thickness of panel: 1,5 to 10 mm.

## **Mounting**

- Make the panel cutout 91 x 91 mm.
- Slide the controller into the panel cutout.
- Insert the flanges for holding into the holes upward and downward or on both sides of the controller.
- Tighten the screws firmly on the flanges.

The controller is now installed, before wiring we recommend to read thoroughly the chapter on the possible sources of interference on [31](#).

Wiring of the controller begins on page [32](#).

- , we recommend you to observe the guidelines described in this chapter.
- [Wiring](#), the description for wiring of the controller.
- [Putting into operation](#), at first power-up you enter the initial menu in which you can configure and set the most important parameters of controller.

According to the procedure you will perform installation, wiring and basic setting of controller. You can find out more details on the scope of the controller and its operation in the following chapters.

For user who have the controller in the complete setting , we recommend to carry out the setting of all the parameters in *service level*, menu **ConE**. **Initial password** for the entry to service level is set to 995.

## 2 Basic terms

To avoid problems in operation of device the user should be able to manage its operation.

### 2.1 Operation and description of controller

On the front panel board you can see 2 displays, 3 control lights (LED diodes) for indicating a status of outputs, 3 control lights (LED diodes) for indicating how a program runs. The device is set and configured via key-buttons.

#### Function of indicators

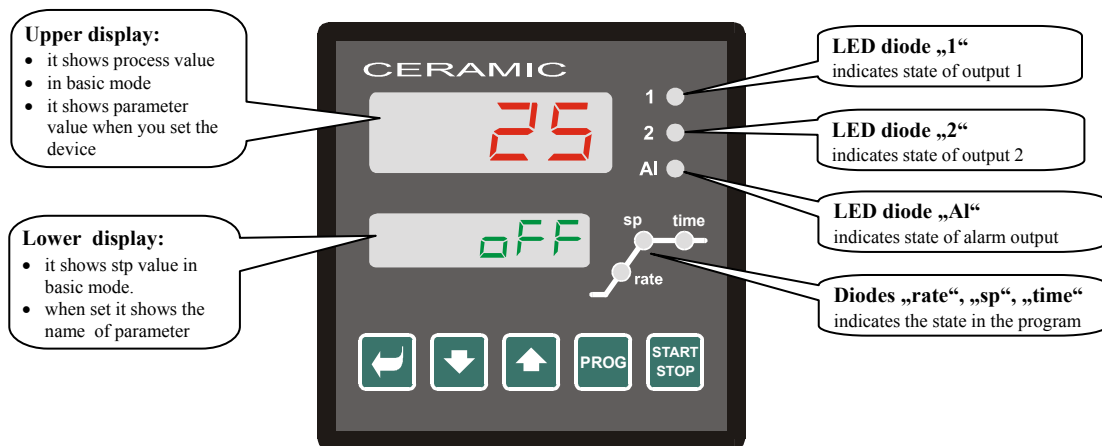

#### Function of key-buttons

The setting of parameters of the controller is performed via key-board. The function of each key-button is as follows:

- key for setting and viewing of parameters of user, operation, configuration and user level. By pressing this key **you confirm the change in configured parameter** and the controller comes to another parameter.
- key for decreasing a value of parameter. The value of parameter is either the figure or abbreviation composed of maximum 4 letters.
- key for increasing a value of parameter.
- key intended for editing a program. By pressing this key **you edit the actual parameter of the program** and the controller comes to another parameter.
- key intended for starting and interrupting a program. By short pressing you enter to menu for starting a program. By long pressing (3 seconds) you enter to menu for starting a program by real time-clock.
- , by pressing both keys for short time the controller returns to basic mode, see page 5. After long pressing (3 seconds) you enter to higher levels of menu (operation, configuration, service).

### 2.2 Information and error messages

Information and error messages are indicated only in *basic mode*, see page 5.

#### Information messages, upper display

- ... error of input sensor or input is not set.

## Information messages, lower display

- **PCLK** ... starting a program by the clock, see page [14](#).
- **Aut1** ... automatic setting / autotuning of PID parameters the set 1 for heating, Pb1A , It1A , dE1A , see page [7](#).
- **Aut2** ... automatic setting / autotuning of PID parameters the set 2 for heating, Pb1b , It1b , dE1b , see page [7](#).
- **Aut3** ... automatic setting / autotuning of PID parameters for cooling Pb2A , It2A , dE2A , see page [7](#).
- **Gsd** ... GSD, process value is outside the soak band, program is held and as soon as process value returns to the defined soak band and the program starts again, see page [16](#).

## Error messages, lower display

If there is a error message indicated the control outputs are switched OFF, the signal output is switched OFF, the alarm output is activated.

- **Err0** ... error in FLASH memory of program. Switch the controller OFF and ON again. If the problem persists, contact your supplier.
- **Err1** ... error in EEPROM memory for configuration and operation parameters. The troubleshooting error can be made by restarting of all parameters in user level. After restart it is necessary to set up all parameters again. This can be done only by an experienced user. If the trouble persists, contact your supplier.
- **Err3** ... error in A/D converter. It can be caused by electrical impulse at input, too low temperature and excessive humidity, ... . Switch the controller OFF and ON again. If the problem persists, contact your supplier.

## 2.3 Overview of levels, menus

For the right function of the controller it is necessary to set up its parameters properly. For better understanding the parameters are sorted out to groups (levels and menus). Level is superior to menu, menu is a part of level (menu **out 1**). The structure of sorting shows the following picture.

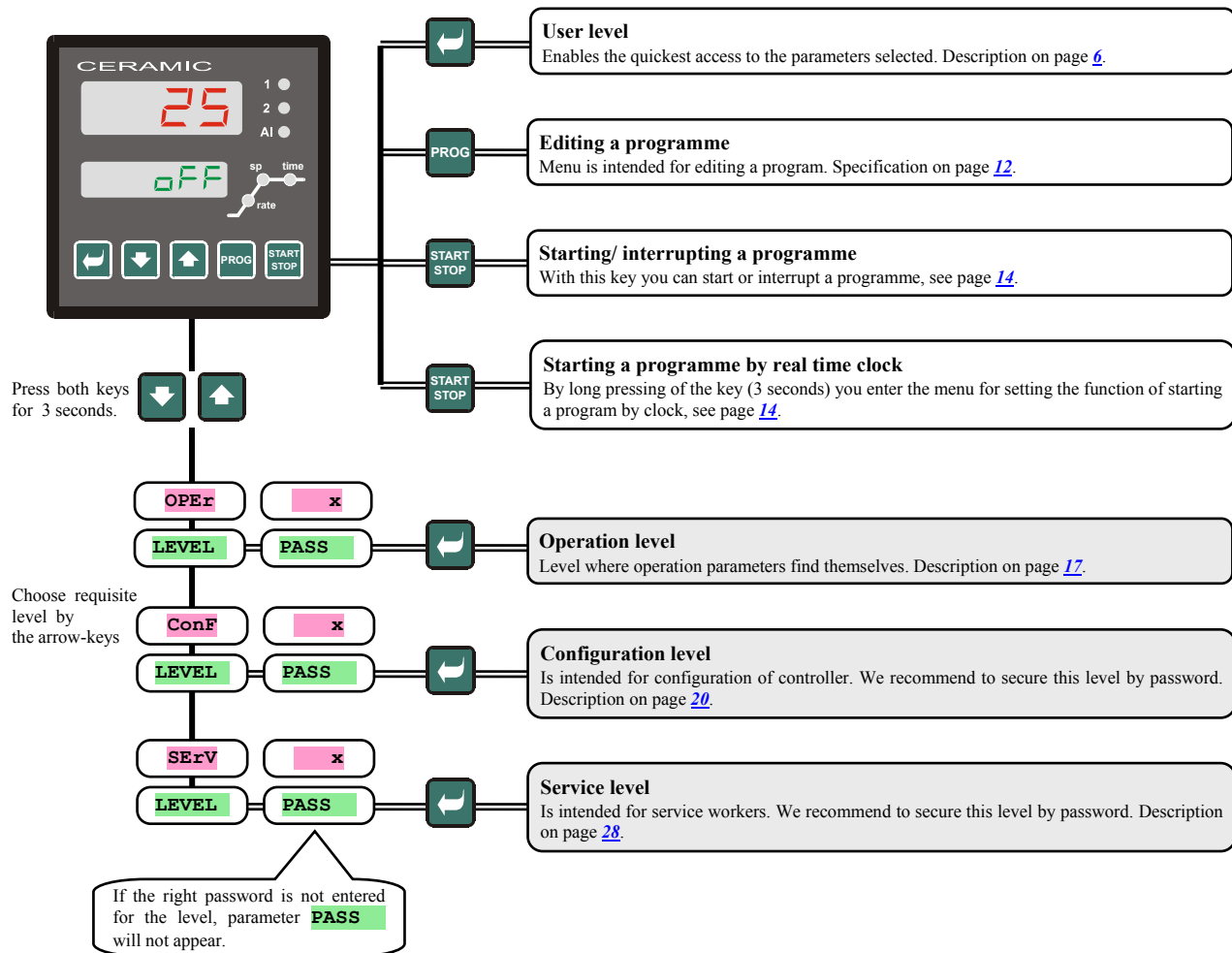

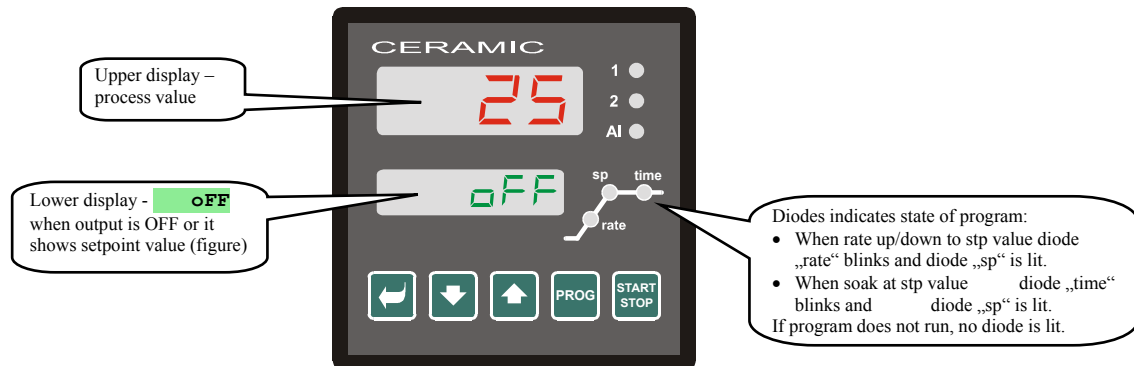

## 3 Basic mode

The controller is in *Basic mode* when powered up (the initial set-up must be performed, see page 35). Upper display shows process value, Lower display shows **OFF** when the output is switched OFF or it shows set point value.



- If there is different reading from **OFF** or setpoint value (figure) on lower display **controller is not in Basic mode** (parameters are being set).
- In *Basic mode* information and error messages appear on lower display, see page 3.

### Return to basic mode

- To return to *Basic mode* press shortly the keys  .
- The controller returns to basic mode automatically if no key is pressed for 60 seconds.

### The state of the controller when no program runs



If no program runs the controller can be set that the control output is switched OFF (it indicates **OFF** on lower display) or the controller can maintain the process value at the set point value (figure appears on lower display). The state of the controller beyond the program is configured via the parameter **SLEEP**:

- **SLEEP** = **OFF**, the control output is switched OFF, heading **OFF** is lit on lower display.
- **SLEEP** = **SP1**, the controller maintains the process value at the set point value (on lower display appears setpoint value that can be modified through key-arrows). Parameter **SLEEP** can be found in *configuration level*, menu **SYS**. Parameter **SLEEP** can be found in *configuration level*, menu **SYS**.

## 4 User level

User level is intended for the quick access to the most common parameters for user.

To enter user level and to go through this level press the key .

To return from user level you must go through all the parameters or by pressing shortly the keys  .

**You can configure freely the structure of user level:**

- you can define which parameters and menus will be in user level,
- you can define on which position these parameters(menus) will be placed,
- the parameters and menus are displayed only in case that their showing has the meaning (e.g. the state of event output is shown only in case that output 2 is set as event output).

### 4.1 Overview of all the parameters and menus of user level

Display	Procedure
<b>ProG</b>	When in program it indicates the number of the program that runs currently.
<b>StEP</b>	When in program it indicates the actual step of the program.
<b>EnSP</b>	When in program it indicates set point value.
<b>trEM</b>	When in program it indicates the time to end of the step.
<b>PCnt 1</b>	Indicates the power in % of the control output 1. It is displayed only then if the output 1 is set as the control output.
<b>PCnt 2</b>	Indicates the power in % of the control output. It is displayed only then if the output 2 is set as the control output.
<b>P ProG</b>	The consumed energy in kWh for the last firing. When program is started the counter is reset and the counting begins from 0.
<b>P tot</b>	The total consumption of energy in kWh. After the value 9999 is reached the counter is reset and the counting begins from 0.
<b>AL oFF</b>	Menu for switching OFF of permanent alarm. Set <b>YES</b> and confirm to switch OFF the permanent alarm.
<b>Ent1</b>	Indicates the state of event output 1 ( <b>oFF</b> ... turned OFF, <b>on</b> ... turned ON). The output can be set by arrow-keys only if program does not run.
<b>Aut</b>	Starting / ending of autotuning / automatic setting of PID parameters: <ul style="list-style-type: none"> <li>• <b>oFF</b>, autotuning / automatic setting of PID parameters is turned OFF.</li> <li>• <b>ht</b>, starting of autotuning / automatic setting of PID parameters for heating</li> <li>• <b>CL</b>, starting of autotuning / automatic setting of PID parameters for cooling.</li> </ul>
<b>dt PER</b>	Period of data storing for datalogger in minutes. Range: 1 to 120 minutes.
<b>dt Sto</b>	Condition for data storing of the measured values in datalogger. <ul style="list-style-type: none"> <li>• <b>oFF</b>, storing is turned OFF</li> <li>• <b>ProG</b>, storing is executed only if program runs</li> <li>• <b>ALMz</b>, storing is executed only at alarm.</li> <li>• <b>Cont</b>, storing is executed constantly.</li> </ul>
<b>AL Lo</b>	Low limit for alarm. Range: <ul style="list-style-type: none"> <li>• -499 up to <b>AL hI</b> °C for <b>AL tYP</b> = <b>ProC</b>.</li> <li>• -999 up to 0 °C for <b>AL tYP</b> = <b>dE</b>.</li> </ul>
<b>AL hI</b>	High limit for alarm. Range: <ul style="list-style-type: none"> <li>• <b>AL Lo</b> up to 2499 °C for <b>AL tYP</b> = <b>ProC</b>.</li> <li>• 0 up to 999 °C for <b>AL tYP</b> = <b>dE</b>.</li> </ul>
<b>dtLoG?</b>	The entry to menu of datalogger. To enter the menu set <b>YES</b> at upper display and confirming. In menu of datalogger you can view the course of firing.
<b>out1 ?</b>	The entry to menu for setting of parameters of the output 1. If you want to enter menu set <b>YES</b> on upper display and confirming. Menu is described on page <a href="#">18</a> .
<b>out2 ?</b>	The entry to menu for setting of parameters of the output 2. If you want to enter menu set <b>YES</b> on upper display and confirming. Menu is described on page <a href="#">19</a> .
<b>CLK ?</b>	The entry to menu for setting of the real time clock. To enter this menu set <b>YES</b> on upper display and confirming. Menu is described on page <a href="#">19</a> .

## 4.2 Datalogger

The controller is equipped with the function for datastoring of measured values, it can store as many as 120 logs. If the memory is full, the oldest data are written over with the newer ones.

Each stored record consists of the following items:

- measured value
- month, day, hour and minute of the log

### Stored logs can be read by 2 ways:

- On displays of the controller in menu **dtLog?**. When the menu is opened on lower display time in format hour and minute is shown and on upper display measured value is shown. You can scroll through single measured values with the arrow-keys.
- Data transferring via communication lines. All necessary information is the manual devoted to communication lines.

### Parameters for the configuration of datalogger

By the parameter **dt PER** you can set and configure the period for storing in minutes.

By the parameter **dt Sto** you can set the condition for datastoring:

- **dt Sto** = **Cont**, data will be stored constantly,
- **dt Sto** = **ALM**, data will be stored at alarm,
- **dt Sto** = **Prog**, data will be stored when program runs,
- **dt Sto** = **oFF**, data are not stored.

The both parameters are located in *operation level* or in *user level*.

## 4.3 Autotuning –automatic setting of PID parameters

The controller is fitted with the function that sets automatically PID parameters.

Autotuning can be started both in program and in controlling to stp value. However, the control output must not be turned OFF.

### Procedure of starting autotuning:

- The controller must switch the control output it means the control output must not be turned OFF (in *basic MODE* there must not be on lower display **oFF**).
- Automatic optimization you can start with parameter **Aut** = **ht** for heating or **Aut** = **cl** for cooling. You will find parameter **Aut** in *operation level* or *user level*. Starting of autotuning is possible only when the particular output is set for PID controlling.
- The controller explores the characteristics of system from switching ON/OFF on the output and determines optimal PID parameters. It can cause an overshoot.
- On lower display blinks **Aut1** (configuration of parameters for heating Pb1A, It1A, De1A), **Aut2** (configuration of parameters for heating Pb1B, It1B, De1B) or **Aut3** (configuration of parameters for cooling Pb2A, It2A, De2A).

### Important:

- Parameters are set Pb1A, It1A, De1A, only when the actual set point value is lower than parameter **SP PID** when both sets of PID parameters are used (**ALGo** = **2PID**).
  - Parameters are set Pb1B, It1B, De1B, only when the actual set point value is higher than parameter **SP PID**.
- Parameters **ALGo** and **SP PID** are in *configuration level*, menu **out1**.

## 4.4 Setting of parameters and menus of user level

The user menu provides user with the simplest access for viewing and configuring of parameters. The list of the parameters which are accessible in user level and their sequence are freely configured.

You can create user level in *configuration level*, menu **uSEr**.

### Example how to create user menu:

If you want to place parameter **Ent1** to the position 1 in *user level* parameter for starting a autotuning **Aut** to the position 2. Proceed as follows:

- Set parameter **StEP 1** = **Ent1**.
- Set parameter **StEP 2** = **Aut**.
- 3 to 12 positions are not used, parameters **StEP 3** to **StEP12** set **no**.

The outcome can be viewed in *user level*.

## 4.5 Monitoring of energy consumption

The controller is equipped with the function for monitoring approximate consumed energy:

- **Total**, reading in kWh is indicated by parameter **P tot**, that can be found in *operation level* or in *user level*.
- **For single firing**, the reading in kWh is indicated with parameter **P ProG** that is found in *operation level* or in *user level*.

### Important:

- For the correct counting of consumed energy you must set the input power of furnace (the equipment) with parameter **POWEr**. Parameter finds itself in *configuration level*, menu **SYS**, see page [22](#).
- The counters of consumed energy **P tot** and **P ProG** have the maximum range 9999. After reaching this value they are reset and the counting continues.
- The counter of consumed energy **P ProG** is automatically reset each time when a program starts.
- The counter **P tot** can be reset in *service level*, menu **SYS**, parameter **CLrP ?**.



# 5 Program

The term „**program**“ can be understood like the requested course of the temperature that user wants to attain.

This chapter is to clarify:

- principals of programming,
- editing a program,
- starting and interrupting a program,
- running a program,
- setting of parameters connected with the program.

## 5.1 Principals of programming

Program (**ProG**) consists of single steps (**StEP**) that goes one after other (program starts with step 1, continues with step 2, ...).

Program is ended up with step **End** (ending a program).

You can edit as many as 20 programs numbered with 1 to 20 and each program can consist of maximum 15 steps.

### Types of steps

The following pictures shows all types of steps you can use for editing:

- ramp up (down) to the temperature (setpoint value - stp) **StPt**, **rAtE**,
- soak at the temperature (stp), **SoAK**,
- end of a program, **End**.

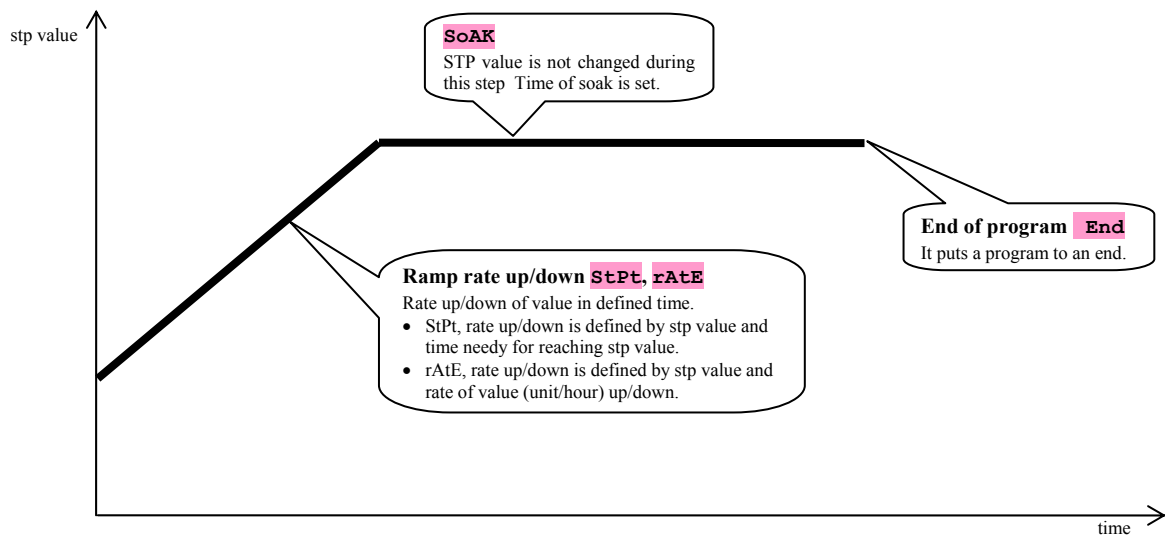

## **StPt, ramp rate up or down of set point value**

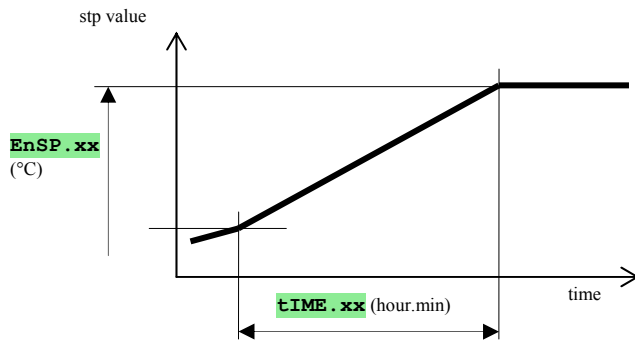

The summary of parameters of step **StPt**

Display	Meaning
<b>EnSP.xx</b>	Final set point value.
<b>tIME.xx</b>	Time needed for reaching set point value, is stated in format hours.minutes.
<b>Ent1.xx</b>	State of the event output 1. Parameter is displayed only when the output 2 is set as the event.

Initial set point value in step **StPt** is the same as the final set point value of preceding (former) step. In case of starting a program the initial set point value is equal to the process value. Time for step is maximum 99 hours 59 minutes.

## **rAtE, rate up and down of set point value**

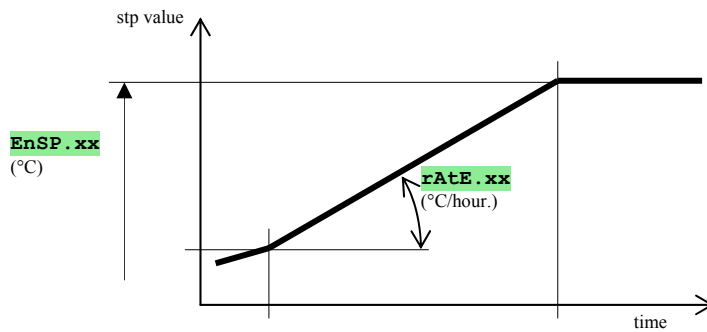

The summary of parameters of step **rAtE**

Display	Meaning
<b>EnSP.xx</b>	Final set point value.
<b>rAtE.xx</b>	Rate of time, is stated in format °C/hour.
<b>Ent1.xx</b>	State of the event output 1. Parameter is displayed only when the output 2 is set as the event.

Initial set point value of step **rAtE** is the same as the final set point value of preceding (former) step. In case of starting a program the initial set point value is equal to the process value. Duration of step is not limited.

## **SoAK, soak on set point value**

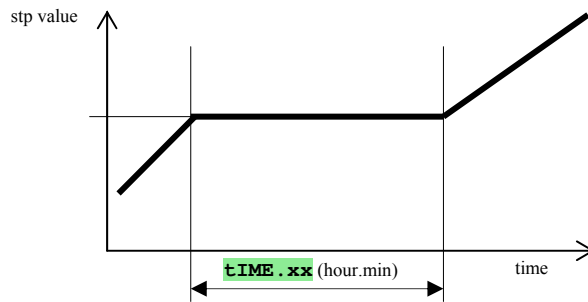

The summary of parameters for step **SoAK**

Display	Meaning
<b>tIME . xx</b>	Time of soak is stated in format hours.minutes.
<b>Ent1 . xx</b>	State of the event output 1. Parameter is displayed only when the output 2 is set as the event.

STP of step **SoAK** is the same as the final STP of previous step. In case of starting a program the set point value is equal to the process value.

Time duration of step is maximum 99 hours 59 minutes.

## **End, ending a program**

The summary of parameters for step **End**

Display	Meaning
<b>Ent1 . xx</b>	State of the event output 1. Parameter is displayed only when the output 2 is set as the event.



The step **End** puts a program to an end and adjusts the event outputs.

## 5.2 Editing a program

Menu for **editing a program** is intended for:

- editing a new program,
- viewing a program that has been edited,
- change of some parameters in the program already edited.

To enter the menu **editing a program** from *basic mode* press the key .

To return from menu **editing a program** to *basic mode* press the both keys  .

The overall menu for **editing a program** is illustrated in the following picture.

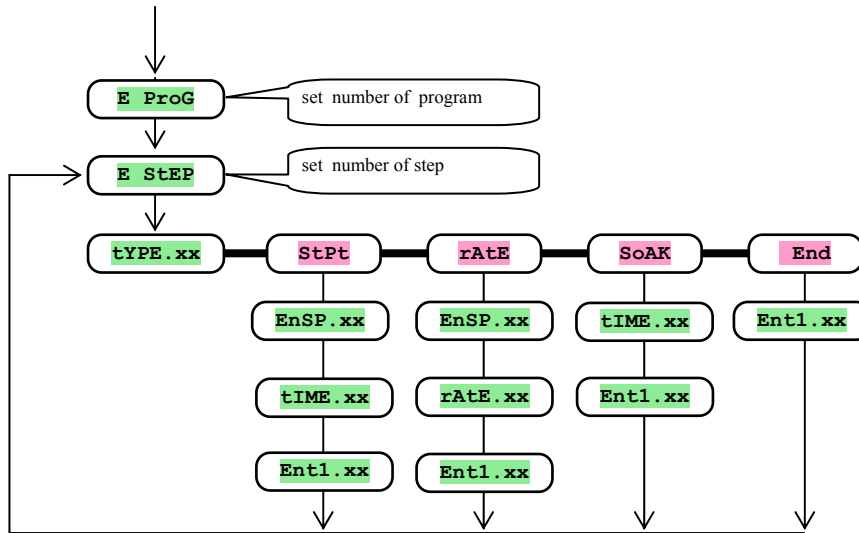

- Parameter **Ent1.xx** is shown only when the output 2 is set as the event output (**out2** = **Ent1**).
- Type of step **StPt** is shown only in case if it is allowed (**rA tYP** = **StPt** or **rA tYP** = **both**).
- Type of step **rAtE** is shown only in case if it is allowed (**rA tYP** = **rAtE** or **rA tYP** = **both**).
- The description for setting parameters **out2** and **rA tYP** you will find in *configuration level*.

### Important:

- At each change of the parameter **rA tYP** it is recommended to check up all edited programs.

How to edit a program – it will be detailed in the following example.

**Example for editing a program:**

- Edit the program to the controller – program is illustrated below and stated in the table .
- Edit the program to the position 2 (program - number 2).
- In configuration level the output 2 is set as the event (**out2 = Ent1**) and both types of steps are allowed for rate up/down (**rA tYP = both**).

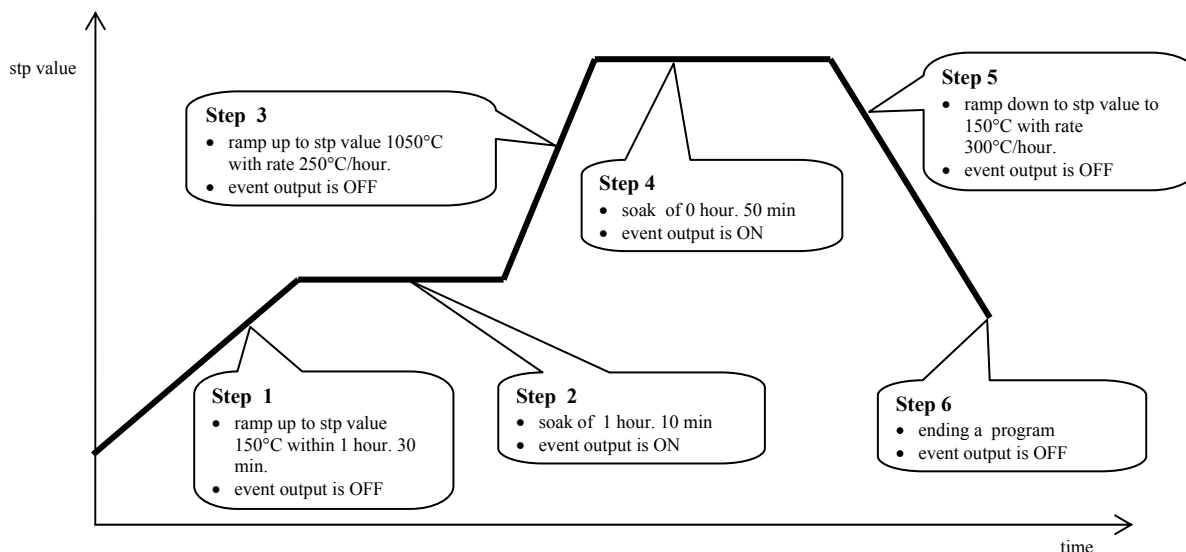

E StEP	tYPE .xx	EnSP .xx	tIME .xx	rAtE .xx	Ent1 .xx
1	StPt	150	1.30		oFF
2	SoAK		1.10		on
3	rAtE	1050		250	oFF
4	SoAK		0.50		on
5	rAtE	150		300	oFF
6	End				oFF
7					
8					

Now you can edit the program to the controller:

- Controller is in **basic mode**, see page 5.
- Press the key „PROG“. On lower display it appears **E Prog**. The procedure for editing a program is in the following table.

Displej	Postup
<b>E Prog</b>	Number of a program, set <b>2</b> , confirm with the key „PROG“.
<b>E Step</b>	Number of step, set <b>1</b> , confirm with the key „PROG“.
<b>tYPE . 1</b>	Type of step 1, set <b>StPt</b> , confirm with the key „PROG“.
<b>EnSP . 1</b>	Set point value of step 1, set <b>150</b> , confirm with the key „PROG“.
<b>tIME . 1</b>	Time needy for reaching value <b>EnSP 1</b> of step 1, set <b>1.30</b> , confirm with the key „PROG“.
<b>Ent1 . 1</b>	State of the event output of step 1, set <b>oFF</b> , confirm with the key „PROG“.
<b>E StEP</b>	Number of step, set <b>2</b> , confirm with the key „PROG“.
<b>tYPE 2</b>	Type of step 2, set <b>SoAK</b> , confirm with the key „PROG“.
<b>tIME . 2</b>	Time of soak of step 2, set <b>1.10</b> , confirm with the key „PROG“.
<b>Ent1 . 2</b>	State of the event output of step 2, set <b>on</b> , confirm with the key „PROG“.

Proceed in the same way for editing another parameters up to step 6

<b>E StEP</b>	Number of step, set <b>6</b> , confirm with the key „PROG“.
<b>tYPE . 6</b>	Type of step 6, set <b>End</b> , confirm with the key „PROG“.
<b>Ent1 . 6</b>	State of the event output of step 6, set <b>oFF</b> , confirm with the key „PROG“.

## 5.3 Starting and ending a program

The program can be started up by the command of operator with keyboard or can be automatically started up by the internal real time clock.

### Starting a programme with keyboard

- Controller is in *basic mode*, see page 5.
- Press shortly the key „START / STOP“. On lower display it appears **ProG**, on upper display you set via key-arrows the number of the program you wish to start and you confirm with the key „START / STOP“.
- The requested program starts.
- Running a program is indicated with diodes „rate“, „sp“ a „time“.

### Starting a program by the internal clock

You can select the program that will be started up by the clock after the time setting.

- Controller is in *basic mode*, see page 5.
- Press the key „START / STOP“ for approx. 3 seconds. On lower display it appears **PCLK**, further you will proceed acc. to the table:

Display	Procedure
<b>PCLK</b>	Set the number of program you wish to start up by clock. If you set <b>OFF</b> , automatic start is not allowed. Confirm with the key „START / STOP“.
<b>Mon</b>	Set month of start of program. If you don't like to set month and day of starting, set <b>OFF</b> . In that case parameter <b>dAY</b> is not displayed and program starts every day. Confirm with the key „START / STOP“.
<b>dAtE</b>	Set day of starting. It is not displayed, if setting is <b>Mon</b> = <b>OFF</b> . Confirm with the key „START / STOP“.
<b>hour</b>	Set hour of starting a program. Confirm with the key „START / STOP“.
<b>Min</b>	Set minute of starting a program. Confirm with the key „START / STOP“.

### Important:

- If you set the automatic starting a program by the clock, on lower display blinks **PCLK**.
- You can not set the automatic starting of the program if another program runs.
- If the program started up by the clock is shorter than 10 minutes, it can be started several times successively one after another.

### To interruption of a program

You can end up a program in this way:

The controller is in *basic mode*, the program is running.

- Press shortly the key „START / STOP“, on lower display it appears **ProG**.
- If you set „Cont“ on upper display and confirm with the key „START / STOP“, **program will continue**.
- If you set „End“ on upper display and confirm with the key „START / STOP“, **program will be ended up**.

## 5.4 The course of the program running

*The run of the program* is indicated with diode lights „rate“, „sp“ and „time“:

- „rate“ blinks, „sp“ is lit, it means that the ramp rate up/down to stp value is running.
- „time“ blinks, „sp“ is lit, it means that the soak on the stp value is running.

The state of the program can be detected with parameters:

- **ProG** ... shows the number of the program that is just running,
- **StEP** ... shows the number of the actual step,
- **EnSP** ... shows the final set point value of the actual step,
- **TrEM** ... shows the time to the end of the step.

These parameters can be made accessible in *user level*.

On lower display stp value is shown, on upper display process/measured value is shown.

The scope of setting and reading parameters, alter. the state of controller are as follows:

- Setting and reading of parameters is allowed in user level.
- Setting and reading of parameters is allowed in operation level.

- Editing and reading programs is allowed. If you change parameters of the program that is just running, the current running step is not changed. The new parameters are accepted only in the following step.
- Setting of automatic start-up of a program by the clock is allowed.
- The interruption and ending a program is allowed.
- Autotuning of PID parameters is allowed.
- Setting the parameters in configuration level **is inhibited**.

## 5.5 Event output Ent1

The event output is intended for controlling of external events (cooling flaps of furnace, fan, ...) by the program.

In particular steps of the program the event output can be switched ON (`Ent1 = on`) or switched OFF (`Ent1 = oFF`).

### Options for configuration of event output

The second output can be configured as the event. Set it in *configuration level*, menu `out2` parameter `out2 = Ent1`.

### State of event output at the interruption of the program

At the interruption of the program, see chapter 5.3, the state of the event output is defined with the parameter `I Ent1` this way:

- `I Ent1 = hoLd`, state of the event output remains unchanged.
- `I Ent1 = oFF`, the event output is switched OFF at the interruption of the program.
- `I Ent1 = on`, the event output is switched ON at the interruption of the program.

### Configuration of event output when program runs

In *operation level* with the parameter `Ent1` (this parameter can be located also in **user level**) you can configure the state of the event output.

When the program runs you can only view the state of the event output.

## 5.6 Signalling via the output 2 when program runs

The second output can be configured and set for **signaling for the run of the program**.

When the program runs, the output is switched ON. When the program does not run the output is switched OFF.

Carry out the setting in *configuration level*, menu `out2` parameter `out2 = SGP`.

## 5.7 Signalling via output 2 when program is ended up

The second output can be configured and set for **signaling when the program is ended up**.

The output is switched ON for 10 seconds after ending or interrupting a program.

Carry out the setting in *configuration level*, menu `out2` parameter `out2 = SGPE`.

## 5.8 Guaranteed Soak Deviation - GSD

The function of GSD helps to maintain the requested course of the program. If the process value leaves the defined Soak Band, **counting down is paused**.

Type of the defined GSD can be configured in *configuration level*, menu **sys**, parameter **GS tYP**:

- **GS tYP = SoAK**, GSD is active only at the beginning of each soak. It means that counting down starts only at the moment when the temperature in the furnace almost reaches the set point value (the deviation of process value from stp value will be smaller than the configured guaranteed soak band (**GS dE**)).

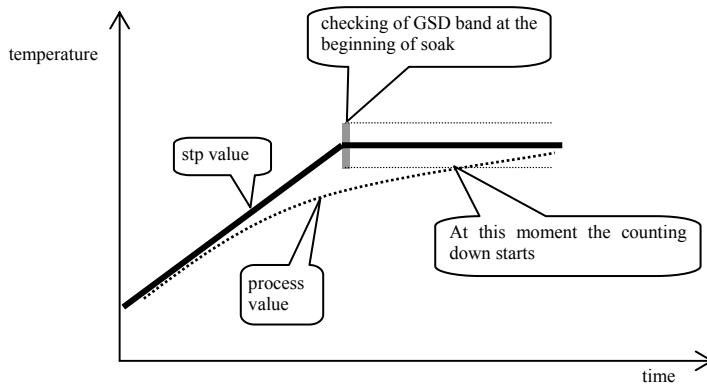

- **GS tYP = trAK**, GSD is active during the whole program. It means that the counting down is paused if the process value leaves the defined soak band **GS dE**.

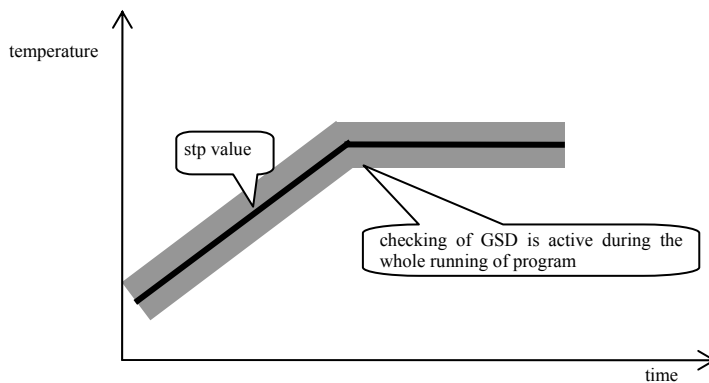





- **GS tYP = OFF**, GSD is turned OFF. It means that the counting down will not be paused.

The soak band **GS dE** can be configured in *configuration level*, menu **sys**, parameter **GS dE**.



## 6 Operation level

In operation level you can set parameters which are available to user.

From basic mode to operation level you will get by pressing the keys   for approx. 3 seconds. On lower display it appears **LEVEL**, on upper display set **oPEr** and confirm with the key . If **PASS** appears on lower display the level is secured with the password. In this case set the right password with the arrow-keys and confirm with the key .

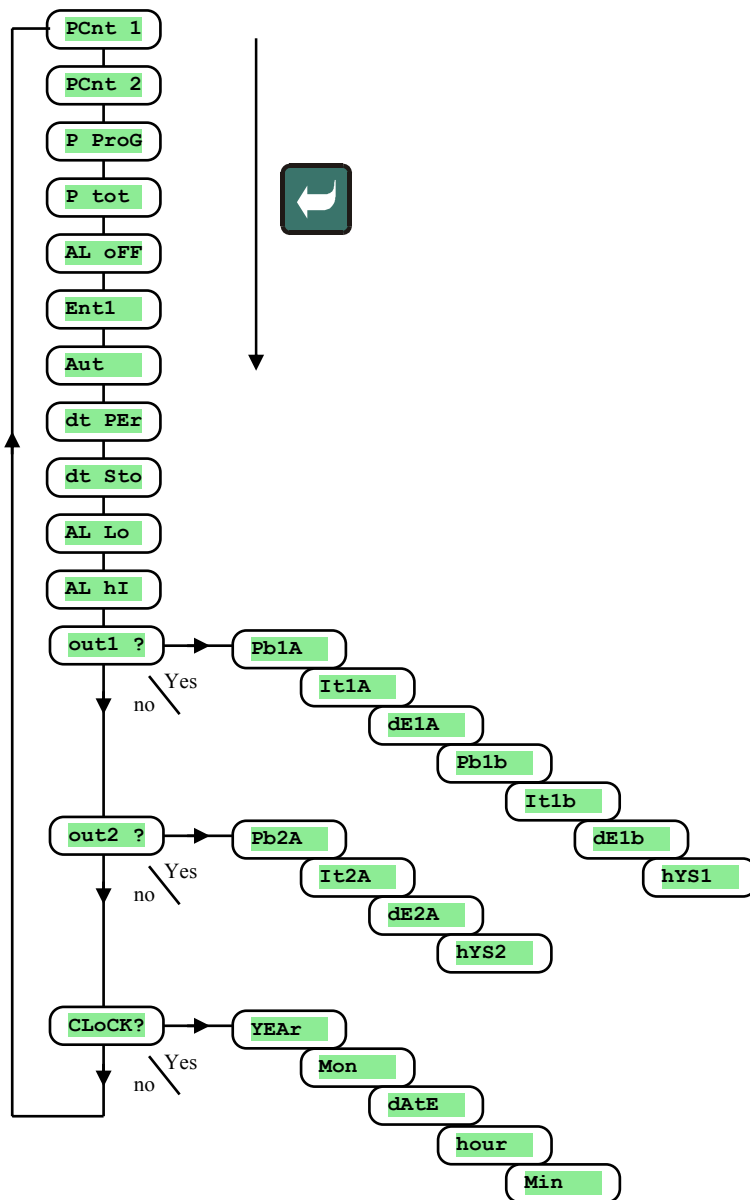

## Menu of operation level

Display	Meaning
PCnt 1	Shows the actual power of the output 1 in %.
PCnt 2	Shows the actual power of the output 2 in %. The output 2 must be set as the control output.
P ProG	Energy consumption in kWh for the last firing. When in program the counter is set to 0 and counting of consumption starts from 0.
P tot	Total consumption in kWh. After reaching value 9999 the counter is reset and starts counting from 0.
AL OFF	You can switch OFF permanent alarm by setting YES and confirm.
Ent1	Appears the state of the event output 1 (OFF ... switched OFF, on ... switched ON). The output can be configured via the arrow-keys if a program does not run.
Aut	Starting / turning OFF of autotuning of PID parameters: OFF, turning OFF of autotuning of PID parameters. ht, starting of autotuning of PID parameters, heating. CL, starting of autotuning of PID parameters, cooling.
dt PER	The period of data storing of measured process values in datalogger in minutes. Range: 1 to 120 minutes.
dt Sto	Condition for data storing of measured process values(data history) in datalogger: OFF, data storing is turned OFF. ProG, storing is executed only if program runs. ALMr, storing is executed only at alarm. Cont, storing is executed constantly.
AL Lo	Low limit of alarm. Range: -499 to AL hI °C for AL tYP = ProC. -999 to 0 °C for AL tYP = dE.
AL hI	High limit of alarm. Range: AL Lo to 2499 °C for AL tYP = ProC. 0 to 999 °C for AL tYP = dE.
out1 ?	The entry to menu for setting of parameters of the output 1.
out2 ?	The entry to menu for setting of parameters of the output 2.
CLoCK?	The entry to menu for setting the real-time clock.

### out1 , menu for parameters of the output 1

Menu is intended for manual setting of PID parameters or for fine tuning of parameters when the controlling is not enough precise.

Display	Meaning
Pb1A	Proportional band, the first set of PID parameters. Range: 1 to 2499 °C.
It1A	Integral value, the first set of PID parameters. Range: OFF, 0.1 to 99.9 minutes.
dE1A	Derivative value, the first set of PID parameters. Range: OFF, 0.01 to 9.99 minutes.
Pb1b	Proportional band, the second set of PID parameters. Range: 1 to 2499 °C.
It1b	Integral value, the second set of PID parameters. Range: OFF, 0.1 to 99.9 minutes.
dE1b	Derivative value, the second set of PID parameters. Range: OFF, 0.01 to 9.99 minutes.
hYS1	Hysteresis, this single parameter is set only for ON/OFF control. Range: 1 to 249 °C.

Parameters Pb1A , It1A , dE1A / Pb2A , It2A , dE2A are switched over with accordance to stp value. The temperature for switching over is set in *configuration level*, menu out1 parameter SWPID . If stp value is lower than SWPID , parameters Pb1A , It1A , dE1A are used, if it is higher, the parameters Pb2A , It2A , dE2A are used.

## **out2** , menu for parameters of the output 2

Menu is intended for manual setting of PID parameters of the output 2 or for the correction of PID parameters after autotuning.

Display	Meaning
<b>Pb2A</b>	Proportional band. Range: 1 to 2499 °C.
<b>It2A</b>	Integral value. Range: <b>OFF</b> , 0.1 to 99.9 minutes.
<b>dE2A</b>	Derivative value. Range: <b>OFF</b> , 0.01 to 9.99 minutes.
<b>hYS2</b>	Hysteresis, this single parameter is set only for ON/OFF control. Range: 1 to 249 °C.



## **CLK** , menu for setting the real time clock

In this menu you can set the real time clock. The clock is not equipped with automatic changeover from standard time to daylight saving time and back in turn.

Display	Meaning
<b>YEAr</b>	Set the actual year.
<b>Mon</b>	Set the actual month.
<b>dAtE</b>	Set the actual day.
<b>hour</b>	Set current hour.
<b>MIn</b>	Set current minute.

# 7 Configuration level

Configuration level is intended for the basic setting of the controller. In this level **the control output is turned OFF** and **alarm, signal and event outputs are deactivated**.

To enter configuration level from basic mode press both the keys   for 3 seconds. On lower display it appears **LEVEL**, on upper display set via the arrow-keys **ConF** and confirm. If **PASS** appears on lower display, configuration level is secured with the password. In this case set the password via the arrow-keys and confirm again.

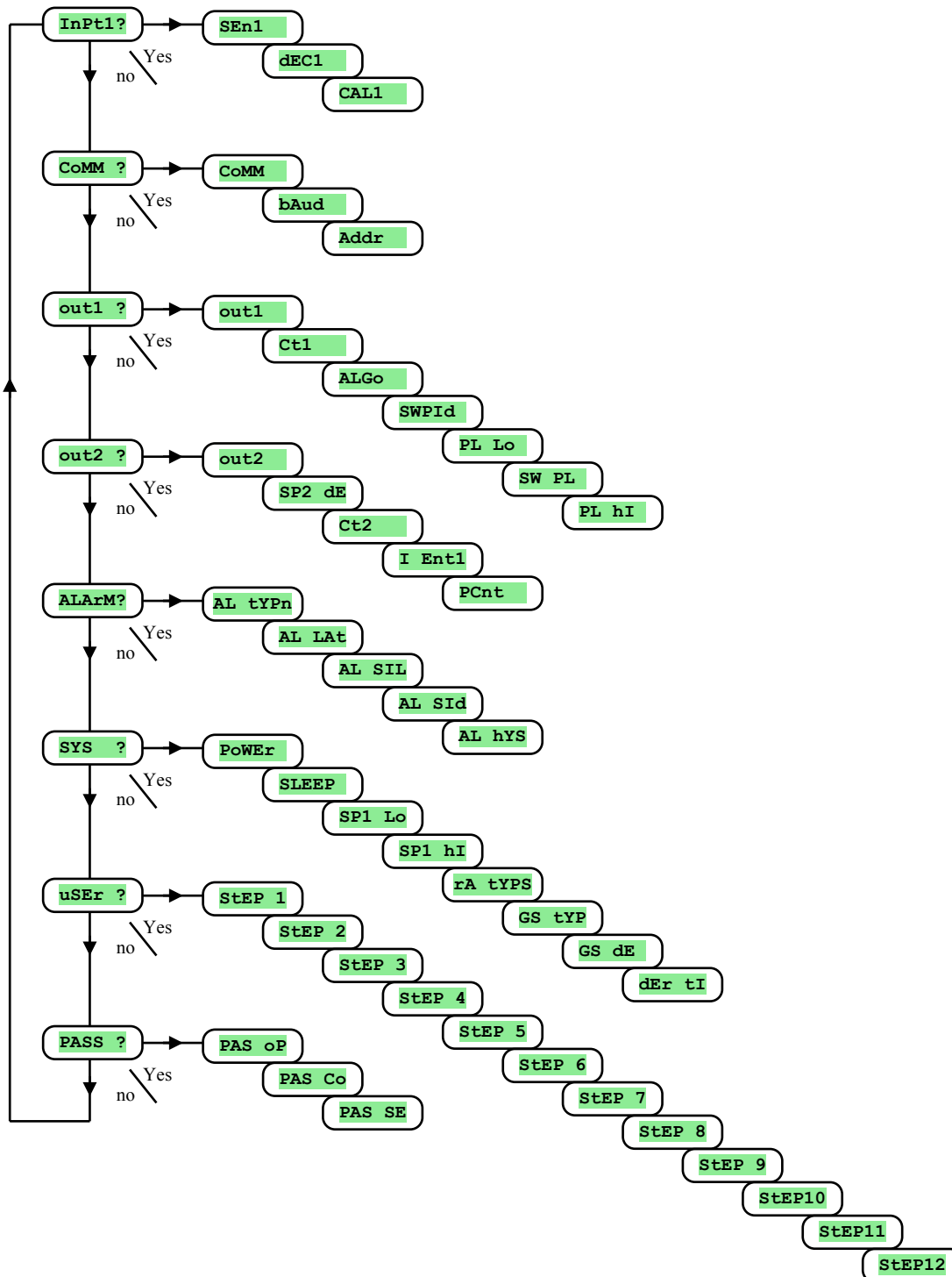

## InPt1 , input setting

Display	Meaning
	Setting of input sensor.
<b>SEn1</b>	<ul style="list-style-type: none"> <li><b>no</b> ... input is not set.</li> <li><b>J</b> ... thermocouple J, range -200 to 900°C.</li> <li><b>K</b> ... thermocouple K, range -200 to 1360°C.</li> <li><b>t</b> ... thermocouple T, range -200 to 400°C.</li> <li><b>n</b> ... thermocouple N, range -200 to 1300°C.</li> <li><b>E</b> ... thermocouple E, range -200 to 700°C.</li> <li><b>r</b> ... thermocouple R, range 0 to 1760°C.</li> <li><b>S</b> ... thermocouple S, range 0 to 1760°C.</li> <li><b>b</b> ... thermocouple B, range 300 to 1820°C.</li> <li><b>C</b> ... thermocouple C, range 0 to 2320°C.</li> <li><b>d</b> ... thermocouple D, range 0 to 2320°C.</li> <li><b>rtd</b> ... rtd sensor ( Pt100), range -200 to 800°C.</li> </ul>
<b>dEC1</b>	Setting of decimal point for displaying. <ul style="list-style-type: none"> <li><b>0</b> ... no decimal point.</li> <li><b>0.0</b> ... 1 decimal point.</li> </ul>
<b>CAL1</b>	Correction of sensor. The set value is added to process value. Range: -999 to 999 °C.

## CoMM , communication line

Display	Meaning
<b>CoMM</b>	Setting of communication line. <ul style="list-style-type: none"> <li><b>SL</b> ... Slave, used for communication PC with controllers.</li> <li><b>MA</b> ... Master, the controller transmits information for the controlling of SLAVE units.</li> </ul>
<b>bAud</b>	Baud rate of the communication is in default setting - 9600Bd.
<b>Addr</b>	Address of the equipment, it is shown when <b>CoMM</b> = <b>SL</b> .

## out1 , output 1

Display	Meaning
<b>out1</b>	Function of the output 1: <ul style="list-style-type: none"> <li><b>oFF</b> ... the output 1 is turned OFF.</li> <li><b>ht</b> ... the heating control, PID controlling.</li> <li><b>ht2</b> ... the heating control, ON/OFF controlling.</li> </ul>
<b>Ct1</b>	Time cycle for switching of the output 1. Range: 1 to 200 seconds.
<b>ALGo</b>	Algoritmus of PID controlling: <ul style="list-style-type: none"> <li><b>PId</b> ... one set of PID parameters is used.</li> <li><b>2PId</b> ... both sets of PID parameters are used.</li> </ul>
<b>SWPId</b>	Limit between PID1 and PID2. Range: -499 to 2499 °C.
<b>PL Lo</b>	Power limit function for the limiting of output power at low measured values, in %. Range: 0 to 100 %.
<b>SW PL</b>	Setting of limit between low and high values of power limit function. Range: -499 to 2499 °C.
<b>PL hI</b>	Power limit function for the limiting of output power at high measured values, in %. Range: 0 to 100 %.

## out2 , output 2

Display	Meaning
<b>out2</b>	Function of the output 2: <ul style="list-style-type: none"> <li><b>oFF</b> ... the output 2 is turned OFF.</li> <li><b>CL</b> ... the cooling control, PID controlling.</li> <li><b>CL2</b> ... the cooling control, ON/OFF controlling.</li> <li><b>Ent1</b> ... the event Nr.1, controlled by program.</li> <li><b>SGP</b> ... signalling of the state that program runs.</li> <li><b>SGPE</b> ... signalling for ending up of program, duration of signalling is 10 seconds.</li> <li><b>A ht</b> ... auxiliary heating.</li> </ul>
<b>dE SP2</b>	Stp value of the output 2 (the deviation from stp value of the output 1). Range: 0 to 1000 °C.
<b>Ct2</b>	Time cycle for switching of the output 2. Range: 1 to 200 seconds.

<b>I Ent1</b>	State of the event output 1 when <b>program is interrupted</b> : <b>hold</b> ... the event output 1 remains unchanged. <b>oFF</b> ... the event output 1 is turned OFF. <b>on</b> ... the event output 1 is turned ON. Parameter is shown only when the output is set as the event.
<b>PCnt</b>	Limiting of power of auxiliary heating. Range: 0 to 100 %.

## **ALArM , alarm output**

Display	Meaning
<b>AL tYP</b>	Function of the alarm output: <b>oFF</b> ... alarm output is turned OFF. <b>ProC</b> ... alarm defined by the absolute value. <b>dE</b> ... alarm defined by the deviation from stp value SP1.
<b>AL Lat</b>	Setting for alarm latching: <b>oFF</b> ... temporary alarm. <b>on</b> ... permanent alarm .
<b>AL SIIL</b>	Setting for alarm silencing at power-up: <b>oFF</b> ... alarm function is active. <b>on</b> ... alarm function is deactivated.
<b>AL SIId</b>	The selection of active limits for alarm: <b>both</b> ... low and high limit is active. <b>hI</b> ... high limit is active. <b>Lo</b> ... low limit is active.
<b>AL hYS</b>	Hysteresis for switching for the alarm output. Range: 1 to 99 °C.

## **SYS , system parameters**

Display	Meaning
<b>POWEr</b>	Power of system under control in kW. This parameter is used for the calculation of consumed energy. Range: 0.0 to 999.0 kW.
<b>SLEEP</b>	State of the controller if a program does not run: <b>oFF</b> ... the controller does not maintain the process value to stp value. <b>SP1</b> ... the controller maintains the process value to stp value SP1.
<b>SP1 Lo</b>	The limit of low range for stp value. Range: -499 to <b>SP1 hI</b> °C.
<b>SP1 hI</b>	The limit of high range for stp value. Range: <b>SP1 Lo</b> to 2499 °C.
<b>rA tYP</b>	Type of step for ramp up/down allowed in program: <b>StPt</b> ... step is defined by stp value and time needy for reaching it. <b>rAtE</b> ... step is defined by stp value and by ramp rate up/down. <b>both</b> ... both steps are accessible/available.
<b>GS tYP</b>	Type of GSD: <b>SoAK</b> ... GSD is active only at the beginning of soak. <b>trAK</b> ... GSD is active during the whole program. <b>oFF</b> ... GSD is turned OFF.
<b>GS dE</b>	Setting of band for GSD about stp value when the program runs. Range: 1 to 999 °C.
<b>dEr tI</b>	It makes the character of derivative value more accurate. The more value is set, the more derivative value is damped down. Range: 1.0 to 100.0 seconds.

## **uSEr** , setting of user menu

Display	Meaning
	Parameter, that is placed on first position in user menu. In brackets it is suggested the displaying of the parameter in user level (on lower 6-figure display): <b>no</b> ... there is no parameter <b>ProG (ProG)</b> ... when in program it indicates the current running program. <b>StEP (StEP)</b> ... when in program it indicates the current running step. <b>EnSP (EnSP)</b> ... when in program it indicates the final set point value. <b>trEM (trEM)</b> ... when in program it indicates the time to the end of the step. <b>PCn1 (PCnt 1)</b> ... indicates the power in % of the control output 1. <b>PCn2 (PCnt 2)</b> ... indicates the power in % of the control output 2. <b>PPrG (P ProG)</b> ... indicates energy in kWh consumed for the last firing. <b>Ptot (P tot)</b> ... indicates total consumed energy in kWh. <b>AoFF (AL oFF)</b> ... function for swithing the alarm OFF . <b>Ent1 (Ent1)</b> ... displaying / controlling of the event output 1. <b>Aut (Aut)</b> ... starting / ending of autotunning of PID parameters. <b>dPER (dt PER)</b> ... datalogger, setting of the period for data storing of measured values. <b>dSto (dt Sto)</b> ... datalogger, setting the condition for data storing. <b>A Lo (AL Lo)</b> ... setting of low limit for alarm. <b>A hI (AL hI)</b> ... setting of high limit for alarm. <b>dLoG (dtLoG?)</b> ... the access to menu of datalogger. <b>out1 (out1 ?)</b> ... the entry to menu of operation parameters – output 1 (Pb1A, It1A, ...). <b>out2 (out2 ?)</b> ... the entry to menu of operation parameter – output 2 (Pb2A, It2A, ...). <b>CLK (CLK ?)</b> ... the entry to menu for setting of the real-time clock.
<b>StEP 1</b>	
<b>StEP 2</b>	Parameter that is placed on 2nd position of user menu. The list is the same as in <b>StEP 1</b> .
<b>StEP 3</b>	Parameter that is placed on 3rd position of user menu. The list is the same as in <b>StEP 1</b> .
<b>StEP 4</b>	Parameter that is placed on 4th position of user menu. The list is the same as in <b>StEP 1</b> .
<b>StEP 5</b>	Parameter that is placed on 5th position of user menu. The list is the same as in <b>StEP 1</b> .
<b>StEP 6</b>	Parameter that is placed on 6th position of user menu. The list is the same as in <b>StEP 1</b> .
<b>StEP 7</b>	Parameter that is placed on 7th position of user menu. The list is the same as in <b>StEP 1</b> .
<b>StEP 8</b>	Parameter that is placed on 8th position of user menu. The list is the same as in <b>StEP 1</b> .
<b>StEP 9</b>	Parameter that is placed on 9th position of user menu. The list is the same as in <b>StEP 1</b> .
<b>StEP10</b>	Parameter that is placed on 10th position of user menu. The list is the same as in <b>StEP 1</b> .
<b>StEP11</b>	Parameter that is placed on 11th position of user menu. The list is the same as in <b>StEP 1</b> .
<b>StEP12</b>	Parameter that is placed on 12th position of user menu. The list is the same as in <b>StEP 1</b> .

## **PASS** , passwords for the entry to higher levels of menu

Display	Meaning
<b>PAS oP</b>	Password for the entry to operation level. If it is set <b>oFF</b> , the entry is not secured with password. <ul style="list-style-type: none"> <li>Range: <b>oFF</b>, 1 to 9999.</li> </ul>
<b>PAS Co</b>	Password for the entry to configuration level. If it is set <b>oFF</b> , the entry is not secured with password. Range: <b>oFF</b> , 1 to 9999.
<b>PAS SE</b>	Password for the entry to service level. If it is set <b>oFF</b> , the entry is not secured with password. Range: <b>oFF</b> , 1 to 9999.

## 7.1 Measurement

The right selection, the installation, the wiring, the location of sensor in the equipment and the corresponding setting of parameters of the controller has the essential importance for the correct function. Parameters for the configuration of the measurement input are in *configuration level*, menu **InPt1**.

### Setting of input sensor

Set the corresponding input sensor in parameter **SEn1**. You will find the survey of input sensors in the chapter Technical parameters, see page 36.

You can set the position of decimal point by parameter **dEC1**. For thermal sensors it is possible to display without decimal point or with 1 decimal point.

Set the calibration of sensor with the parameter **CAL1**. The set value is added to process/measured value.

You can set the limit for set point value in *configuration level*, menu **sys**, parameters **SP1 Lo** a **SP1 hI**.

### Important:

- Thermocouple and RTD inputs have the detection of improperly wired sensor. When the sensor is open or broken, the control output is turned OFF, the alarm output is activated, the signal output is deactivated..

## 7.2 Controlling, the control output

You can select in the controller ON/OFF (2 state) or PID controlling for heating or cooling. If PID controlling is set, you can use the autotuning function for finding optimal PID parameters, see page 7 and the power limit function, see page 25. Parameters for configuration of the control output 1 are in *configuration level*, menu **out1**, of the control output 2 in menu **out2**.

### ON/OFF controlling

ON/OFF control is selected by setting **out1** = **ht2** (heating control) or **out2** = **CL2** (cooling control). It is used for less exacting application. It is not possible to achieve zero hysteresis value on principle. The process value rises and drops about set point value in the characteristic way.

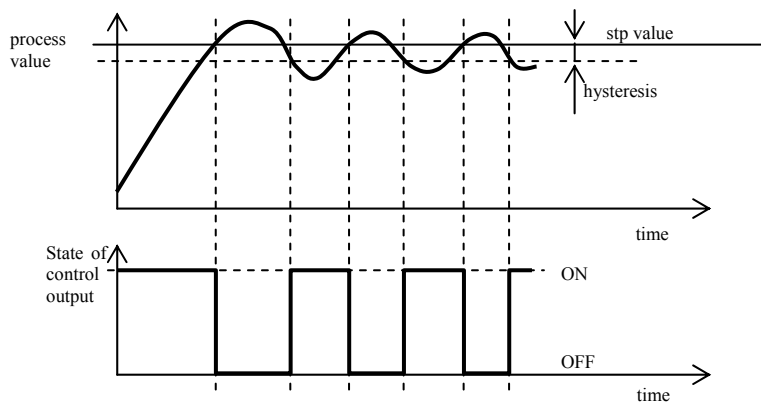

### PID controlling

PID control is selected by setting **out1** = **ht** (heating) or **out2** = **CL** (cooling). It provides the precise control. For the correct function of the controller, however, it is necessary to set properly PID parameters. Autotuning for setting of PID parameters is described on page 7.

PID parameters have the following meaning:

- **Pb** **proportional band**, is set in measured units. It is the band about the set point value in which the controller keeps the temperature.
- **It** **integral factor**, in minutes. Integral factor compensates the loss of system. A **low** integral value causes a **fast** integrating action.
- **dE** **derivative factor**, in minutes. Derivative responses to fast changes and tries to react against them. The **more** value is, the **more** derivative factor reacts.



If the control output is 2 state (ON/OFF) (relay or SSR), the power is (given in %) transferred to the output with so called pulse width modulation. In each time cycle (parameter **ct1**, that is in *configuration level*, menu **out1**) the control output is switched ON once and once OFF. The more the power is necessary, the wider the width of switching is. The output responses are illustrated in the third part of the drawing.

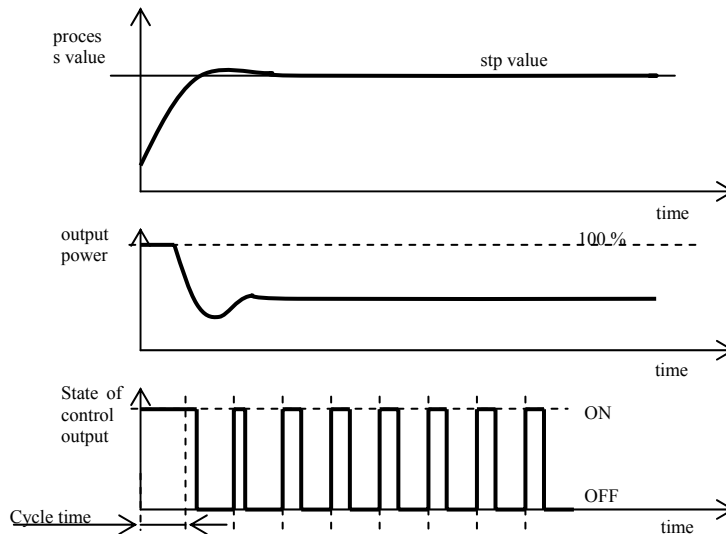

#### Example of pulse width modulation of the output:

- Time cycle is 10 seconds, the power requested is 30%. The output is ON for 3 seconds and OFF for 7 seconds.
- Time cycle is 10 seconds, the power requested is 5%. The output is ON for 0,5 second and OFF for 9,5 seconds.

#### Important:

- The duration of time cycle has the influence on the quality of control. The longer the cycle is, the less the quality of control is.
- If the electromechanical unit (relay, switching contactor) is used for the control output, the duration of time cycle must be set longer with regard to lifetime of switch.

#### Power limit function

You can improve the quality of control by limiting of the output power. Power limit function can be used only for heating.

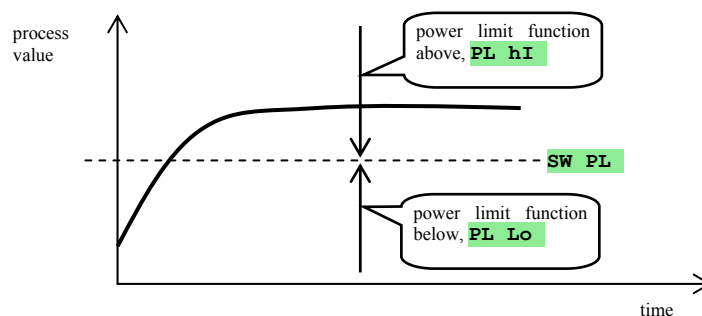

#### Example how to use the power limit function:

When rising at set point value the big overshoot occurs. One of possible solution is the power limit in the vicinity of set point value. The procedure is the following:

- Find out the power supplied to the stable system.
- Set the switcher **SW PL** on the value by several °C less than set point value.
- Set power limit **PL LO** to 100%.
- Set power limit **PL hI** approx. by 10 to 20% higher than the power supplied to the stable system.

## 7.3 Alarm

The third output (output 3) is alarm.

The configuration parameters of the output you will find in *configuration level*, menu **ALARM**, setting of alarm limits **AL Lo** and **AL hI** you will find in *user level or operation level*.

### Setting of alarm output

You can set this function with parameter **AL tYP**:

- **AL tYP** = **oFF**, alarm output is turned OFF.
- **AL tYP** = **ProC**, alarm defined by the absolute value.
- **AL tYP** = **dE**, alarm limits are set as the deviation from stp value.

### Important:

- Relay in standby MODE means **active alarm**.
- When controller is switched OFF, error of sensor, error of controller the alarm is active.

### Alarm defined by the absolute value of temperature **AL tYP** = **ProC**.

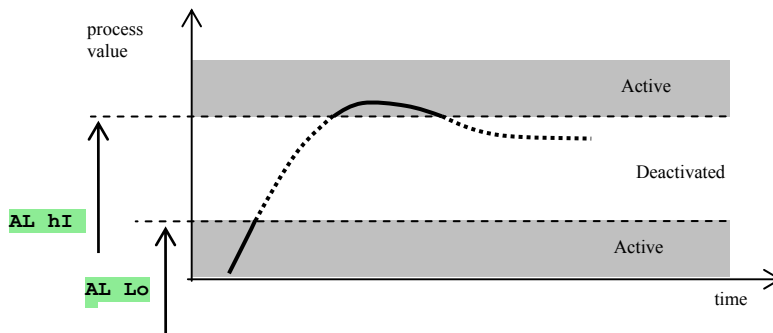

### Alarm defined by the deviation from stp value **AL tYP** = **dE**.

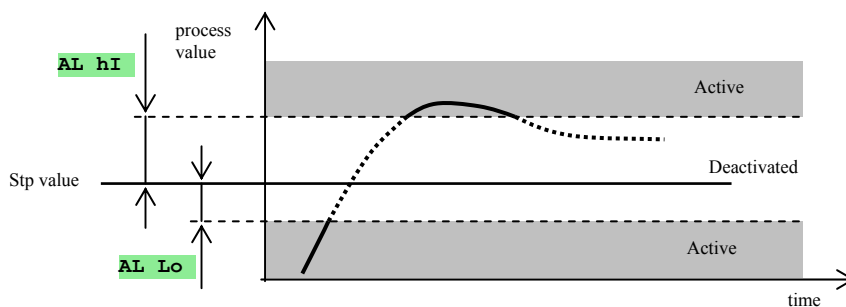

## Temporary, permanent (latched) alarm

Alarm can be temporary (**AL Lat** = **OFF**) or permanent (**AL Lat** = **on**).

- Temporary alarm will turn automatically off when the alarm condition is over.
- Permanent alarm is turned ON even when the alarm condition is over. Turn OFF permanent(latched) alarm when the alarm condition is over by the function **AL OFF**, that is found in *user level* or *operation level*. Permanent alarm is also turned off after the supply voltage interruption.

## Silencing of alarm

Silencing of alarm can be used to disable alarm at startup rising to set point value. This state should not be evaluated as error because the system is not yet stable. This function is set with the parameter **AL SIL**:

- **AL SIL** = **OFF**, function is not active.
- **AL SIL** = **on**, alarm can be activated after the process value at startup rising reached the allowed range for the first time (between alarm limits).

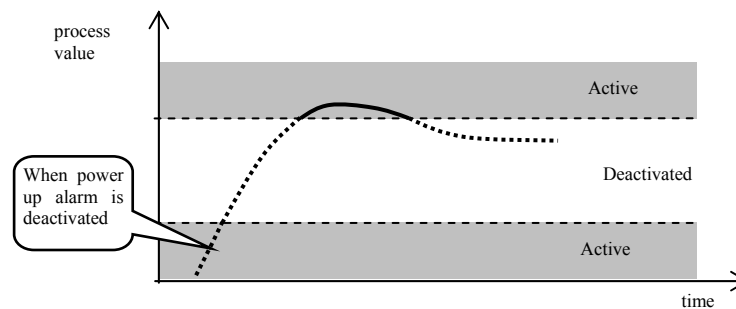



## Active sides of alarm

With parameter **AL Sid** you can choose the active side of the alarm:

- **AL Sid** = **both**, both sides (limits) are active.
- **AL Sid** = **hI**, only high alarm side (limit) is active.
- **AL Sid** = **Lo**, only low alarm side (limit) is active.

# 8 Service level

Service level is intended for service workers. In this level the control output is switched OFF and alarm and event output is deactivated.

You can get to service level from basic mode by pressing the keys   for 3 seconds. On lower display it appears LEVEL, on upper display set SerV and confirm. If it appears PASS on lower display, level is secured with password. In this case set the right password with the arrow-keys and confirm again.

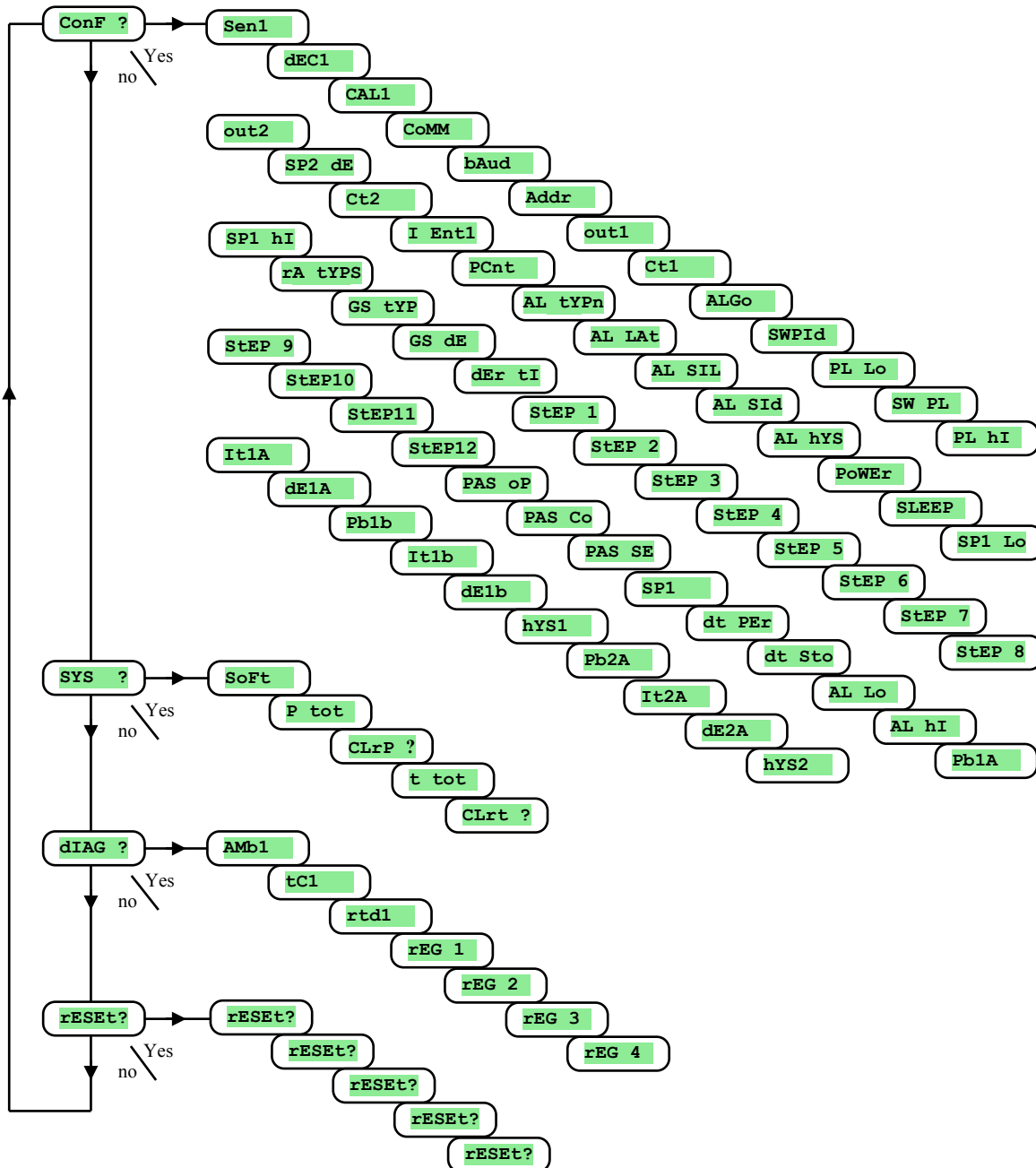

## **ConF** , **setting of configuration**

In this menu all configuration parameters of the controller are accessible. The description of parameters are in the chapter above.

Menu is intended for the complete configuration of controller.

## **SYS** , **system menu**

Display	Meaning
<b>SoFt</b>	The number of software version.
<b>P tot</b>	Total consumption in kWh. After reaching 9999 the counter is reset and the counting starts from 0.
<b>CLrP ?</b>	To reset <b>P tot</b> . Set <b>YES</b> and with confirmation the counter is reset <b>P tot</b> .
<b>t tot</b>	Total time of the control output in hours. Simply it can be said that it is the time of switching ON of the control output.
<b>CLrt ?</b>	To reset <b>t tot</b> . Set <b>YES</b> and with confirmation the counter is reset <b>t tot</b> .

## **DIAG** , **diagnostics of menu**

Display	Meaning
<b>AMb1</b>	Actual ambient temperature..
<b>tC1</b>	Measured voltage, thermocouple input 1. Range 60mV.
<b>rtd1</b>	Measured resistance, resistance input 1. Range 350 Ω.
<b>rEG 1</b>	Parameters needy for manufacturer.
<b>rEG 2</b>	
<b>rEG 3</b>	
<b>rEG 4</b>	

## **rESET** , **editing of initial parameters**

Display	Meaning
<b>rESET?</b>	Editing of initial parameters is the significant action to controller's setting. First it must be confirmed by 4x setting <b>YES</b> , and then the selection of initiation follows.
<b>rESET?</b>	
<b>rESET?</b>	
<b>rESET?</b>	
<b>rESET?</b>	The selection of initiation: <b>no</b> ... no setting of initiation. <b>ConF</b> ... initial configuration (operation, configuration and service level). <b>ProG</b> ... initiation of programs. <b>dAtA</b> ... initiation of data in back-up memory (state of controller, consumed energy, ...). <b>dLoG</b> ... deleting measured values in datalogger. <b>All</b> ... initiation of configuration and programs. After this step the restart of the controller happens.

## 9 Table of parameters

In this table the parameters are sorted out to groups, in the same sequence as the survey of the parameters in *service level*. Write down your own complete setting of controller to the table below.

SEn1	
dEC1	
CAL1	
CoMM	
bAud	
Addr	
out1	
Ct1	
ALGo	
SWPId	
PL Lo	
SW PL	
PL hI	
out2	
SP2 dE	
Ct2	
I Ent1	
PCnt	

AL tYPn	
AL LAt	
AL SII	
AL SIId	
AL hYS	
POWEr	
SLEEP	
SP1 Lo	
SP1 hI	
rA tYPS	
GS tYP	
GS dE	
dEr tI	
StEP 1	
StEP 2	
StEP 3	
StEP 4	
StEP 5	
StEP 6	
StEP 7	
StEP 8	
StEP 9	
StEP10	
StEP11	
StEP12	

PAS oP	
PAS Co	
PAS SE	
SP1	
dt PEr	
dt Sto	
AL Lo	
AL hI	
Pb1A	
It1A	
dE1A	
Pb1b	
It1b	
dE1b	
hYS1	
Pb2A	
It2A	
dE2A	
hYS2	

# 10 Installation

The controller is designed to be mounted to the panel cutout. Slide the controller into the cutout and fix it with 2 flanges, that are supplied with the controller. The installation requires the access to the back of the panel.

## **Mounting dimensions**

- Width x height x overall length: 96 x 96 x 121 mm (including terminalboard).
- behind panel length: 114 mm (including terminalboard).
- Cutout in the panel: 91 x 91 mm.
- The thickness of panel: 1,5 to 10 mm.

## **Mounting**

- Make the panel cutout 91 x 91 mm.
- Slide the controller into the panel cutout.
- Insert the flanges for holding into the holes upward and downward or on both sides of the controller.
- Tighten the screws firmly on the flanges.

The controller is now installed, before wiring we recommend to read thoroughly the chapter on the possible sources of interference on [31](#).

Wiring of the controller begins on page [32](#).

## 10.1 Principals for installation

There are many possible sources of interference in environment of the controller. Among the most harmful sources of interference are the following:

- Equipment with inductive load, e.g. electromotors, winding of relays and breakers, ... .
- Thyristors and other semiconductor equipment .
- Welding devices.
- Wires carrying high currents.
- Fluorescent lightings and neon lights.

## 10.2 Reduction of influence of interference

Making a design try to observe these guidelines:

- All wires of power supply voltage and power wires carrying high currents must be lead separately from signal leads (e.g. thermocouple lead wire, communication lines). Minimum distance between these types of wires should not be smaller than 30 cm.
- If signal and power wires cross each other it is suitable for them to be crossed in right angle.
- From the beginning try to find the possible sources of interference and keep the wires away from them.
- Do not install relays and breakers very close to the controller.
- Do not use supply voltage for the controller also for supplying inductive and phase angle control equipment. Twisted and shielded wires should be used for signal leads. Shielding should be earthed several times. When necessary the uninterruptible power sources (UPS) could be used.

# 11 Wiring

To avoid potential electric shock, use safety practices laid down by national standards when wiring and connecting this unit to a power source. Failure to do so could result in such damage, and / or injury. The wiring must be done only by the authorized person.

If there is any default of the device could cause a damage, the equipment with the controller must be fitted with the independent protection unit (thermal cut-out).

## Supply voltage

Before you connect the unit to a supply power source, check the level of supply voltage.

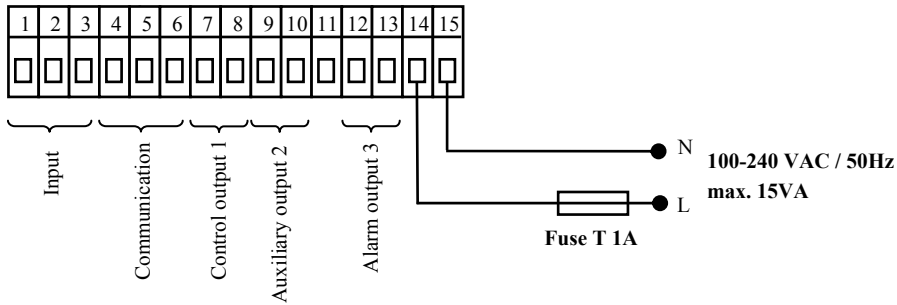

The controller is intended for use in industrial or in laboratory equipment.

## Measuring input (InPt1)

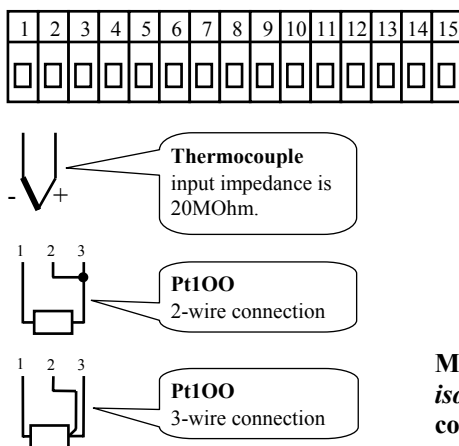

**Measuring input is not isolated from the ground of controller**



## Communication line (CoMM)

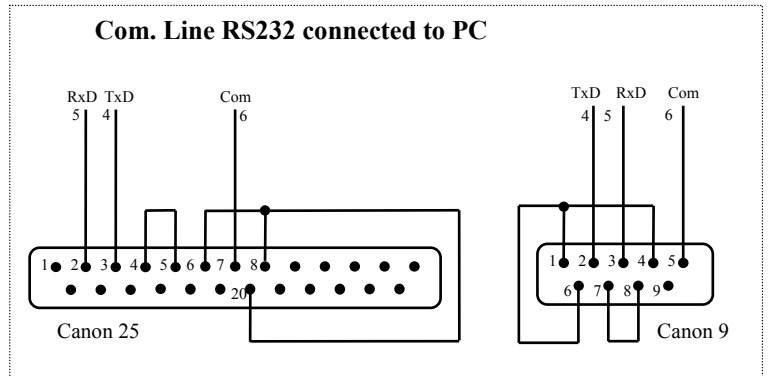
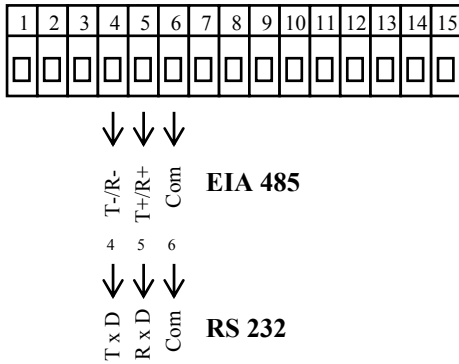

**Communication is galvanically isolated from the ground**

## Output 1 (out1)

**SSD**  
dc voltage

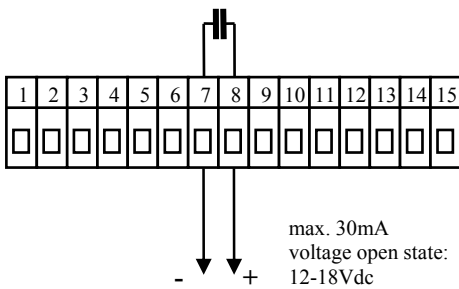

**SSD is not isolated from controllers ground**

**RELAY**  
Relay output

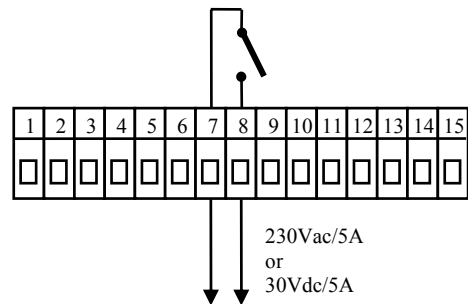

**RELAY output is galvanically isolated from the ground of the controller. For this output it is necessary to fix the wires in the way that in case of loosening the wire from the terminal the insulation would not be reduced between supply voltage and safety voltage.**

## Auxiliary output 2 (out2)

SSD  
dc voltage

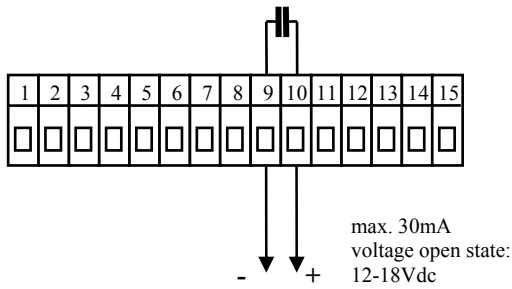

SSD is not isolated from controllers ground

RELAY  
Relay output

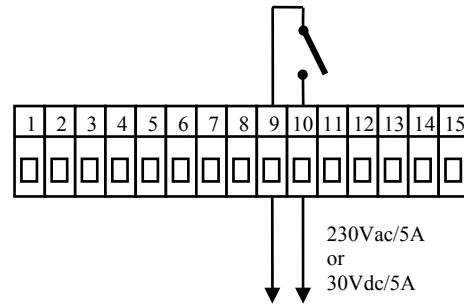

RELAY output is galvanically isolated from the ground of the controller. For this output it is necessary to fix the wires in the way that in case of loosening the wire from the terminal the insulation would not be reduced between supply voltage and safety voltage.

## Alarm output (ALArM)

Relay output

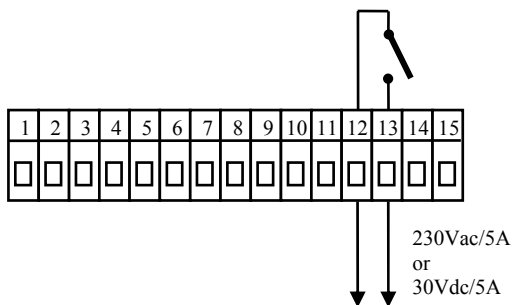

RELAY output is galvanically isolated from the ground of the controller. For this output it is necessary to fix the wires in the way that in case of loosening the wire from the terminal the insulation would not be reduced between supply voltage and safety voltage.

## 12 Putting into operation

**The initial set-up can be done only by the qualified and authorised person.  
The wrong set-up can cause serious damage.**

When you power the controller up for the first time, you must enter the most necessary data to the controller for its problem-free operation:

- type of sensor, position of decimal point.
- operational range of set point value.
- set-up for the control output.

### 12.1 Guidelines

Let's suppose that the controller is installed in the panel and you have just power it up for the first time. Parameters of initial operation are the following:

- **SEn1**, set input sensor. The description of this parameter see on page [21](#).
- **out1**, setting of the control output. The description of this parameter see on page [21](#).
- **SP1 Lo**, set low limit of range of stp value. We recommend to leave 0.
- **SP1 hI**, set high limit of range of stp value. We recommend to set maximum working temperature of equipment. he operator can not set higher stp value than this value of parameter.
- Further information about input setting you will find on page [23](#), information about output setting on page [24](#).

#### **Important:**

- All the parameters that were set in the initial operation can be later changed in *configuration level*.

# 13 Technical parameters

The controller is intended for use in industrial or laboratory equipment, the category of pollution / overvoltage II.

## **Controlling**

- PID, PI, PD, P controlling, autotuning/automatic setting of PID parameters,
- 2-state (ON/OFF) control,
- control of heating or cooling .

## **Alarm**

- absolute or relative defined by the set point value,
- temporary or permanent alarm,
- silencing of alarm at startup of the controller,
- selection of limits high/low, low, high.

## **Controlling/regulation to set point (stp) value**

- program controlling, 20 programs, 15 steps,
- control to the constant set point value.

## **Indicators and keys**

- one 4-figure LED display 14 mm, one 6-figure display 10 mm,
- 3 LED indicating diodes of outputs, 3 LED indicating diodes for program,
- 5 keys, setting is done via menu.

## **Sensors, inputs**

Thermal input is thermocouple or rtd, the detection of bad-wired/broken sensor:

- **no** ... no input is set,
- **J** ... thermocouple J, range -200 to 900°C,
- **K** ... thermocouple K, range -200 to 1360°C,
- **t** ... thermocouple T, range -200 to 400°C,
- **n** ... thermocouple N, range -200 to 1300°C,
- **E** ... thermocouple E, range -200 to 700°C,
- **r** ... thermocouple R, range 0 to 1760°C,
- **s** ... thermocouple S, range 0 to 1760°C,
- **b** ... thermocouple B, range 300 to 1820°C,
- **c** ... thermocouple C, range 0 to 2320°C,
- **d** ... thermocouple D, range 0 to 2320°C,
- **rtd** ... sensor rtd (Pt100), range -200 to 800°C, 2 or 3-wire connection, DIN curves.

## **Output 1, 2**

- open collector / DC driver, 12 – 18 VDC for switching ON, max. 30 mA.
- Electromechanical relay, 230Vac/5A or 30Vdc/5A, switching ON, without RC suppression unit.

## **Alarm output**

- electromechanical relay, 230VAC/5A or 30VDC/5A, switching ON, without RC suppression unit.

## **Communication lines**

- RS 232, galvanically isolated, protocol Modbus RTU,
- EIA 485, galvanically isolated, protocol Modbus RTU.

## **Accuracy of inputs**

- $\pm 0,1\%$  of span/range (min. 540°C) ,  $\pm 1$  digit at 25°C  $\pm 3$ °C of ambient temperature and at  $\pm 10\%$  rated supply voltage,

- temperature stability  $\pm 0,1^{\circ}\text{C}/^{\circ}\text{C}$  in ambient,
- voltage stability  $\pm 0,01\%/%$  of change in supply voltage.

### **Supply voltage**

- 100 to 240 VAC 50 Hz, internal slow fuse 2 A/250 V,
- input power max. 6 VA,
- data stored in memory upon power failure.

### **Operating environment**

- 0 to 50  $^{\circ}\text{C}$ ,
- 0 to 90 % relative humidity, non-condensing.

### **Shipping and storage**

- -20 to 70  $^{\circ}\text{C}$ .

### **Dimensions**

- width x height x length, 96 x 96 x 121 mm,
- depth behind panel surface 114 mm,
- cutout into the panel 91 x 91 mm, the thickness of the panel, 1,5 to 10 mm.

## **13.1 Warranty**

The supplier provides 36-month warranty on defects in material and workmanship on this controller with the exception on defects caused by mechanical or electrical wearing out of the outputs. This warranty does not also apply to damage resulting from inappropriate transportation and storage, misuse, wrong wiring, ambient influences (especially effects of electrical overvoltage, electrical values and temperatures of inadmissible intensity, chemical materials, mechanical damage) electrical or mechanical overloading of inputs and outputs.

## **13.2 Description of model**

### **MtCer - a b - c d e - f g h**

#### **a: input**

T = Thermal input

#### **b: auxiliary input / output**

0 = None

X = Communication line RS 232

A = Communication line EIA 485

#### **c: output 1**

K = Open collector/switched dc

R = Electromechanical relay

P = Current 0-20 mA, 4-20 mA

N = Voltage 0-5 V, 0-10 V

#### **d: output 2**

K = Open collector/switched dc

R = Electromechanical relay

P = Current 0-20 mA, 4-20 mA

N = Voltage 0-5 V, 0-10 V

#### **e: alarm output**

R = Electromechanical relay

#### **f, g, h: version of SW**

# 14 Index

<b>1</b>	<b>Introduction</b>	<b>2</b>
<b>2</b>	<b>Basic terms</b>	<b>3</b>
2.1	Operation and description of controller	3
2.2	Information and error messages	3
2.3	Overview of levels, menus	4
<b>3</b>	<b>Basic mode</b>	<b>5</b>
<b>4</b>	<b>User level</b>	<b>6</b>
4.1	Overview of all the parameters and menus of user level	6
4.2	Datalogger	7
4.3	Autotuning –automatic setting of PID parameters	7
4.4	Setting of parameters and menus of user level	8
4.5	Monitoring of energy consumption	8
<b>5</b>	<b>Program</b>	<b>9</b>
5.1	Principals of programming	9
5.2	Editing a program	12
5.3	Starting and ending a program	14
5.4	The course of the program running	14
5.5	Event output Ent1	15
5.6	Signalling via the output 2 when program runs	15
5.7	Signalling via output 2 when program is ended up	15
5.8	Guaranteed Soak Deviation - GSD	16
<b>6</b>	<b>Operation level</b>	<b>17</b>
<b>7</b>	<b>Configuration level</b>	<b>20</b>
7.1	Measurement	24
7.2	Controlling, the control output	24
7.3	Alarm	26
<b>8</b>	<b>Service level</b>	<b>28</b>
<b>9</b>	<b>Table of parameters</b>	<b>30</b>
<b>10</b>	<b>Installation</b>	<b>31</b>
10.1	Principals for installation	31
10.2	Reduction of influence of interference	31
<b>11</b>	<b>Wiring</b>	<b>32</b>
<b>12</b>	<b>Putting into operation</b>	<b>35</b>
12.1	Guidelines	35
<b>13</b>	<b>Technical parameters</b>	<b>36</b>
13.1	Warranty	37
13.2	Description of model	37
<b>14</b>	<b>Index</b>	<b>38</b>